



MARCHINI CASSETTE FOLDING ARM AWNING

Compact, reliable and perfectly finished the Marchini is designed, engineered and manufactured utilising the very latest in German technology.

- ▶ The ergonomically designed full cassette provides the fabric and components complete protection from sun, humidity and poor weather conditions whilst in the retracted position.
- ▶ Completely concealed mounting brackets do not inhibit the contemporary, clean design and allows for the Marchini to blend with any façade.
- ▶ Maximum fabric tension is maintained by virtue of a heavy duty spring mechanism within the arm assembly.
- ▶ Our textiles offer the very best compromise between visibility and light transmission while providing incomparable weather resistance and ease of maintenance.
- ▶ Designed, engineered and manufactured in Germany. Certified ISO 9001: Safety tested by German TUV (Product Service).  MADE IN GERMANY



MARCHINI CASSETTE FOLDING ARM AWNING SPECIFICATIONS

Please note illustrations are not to scale. All measurements are in millimetres. Please contact your Viva Sunscreens representative for additional information.

FIXING METHODS

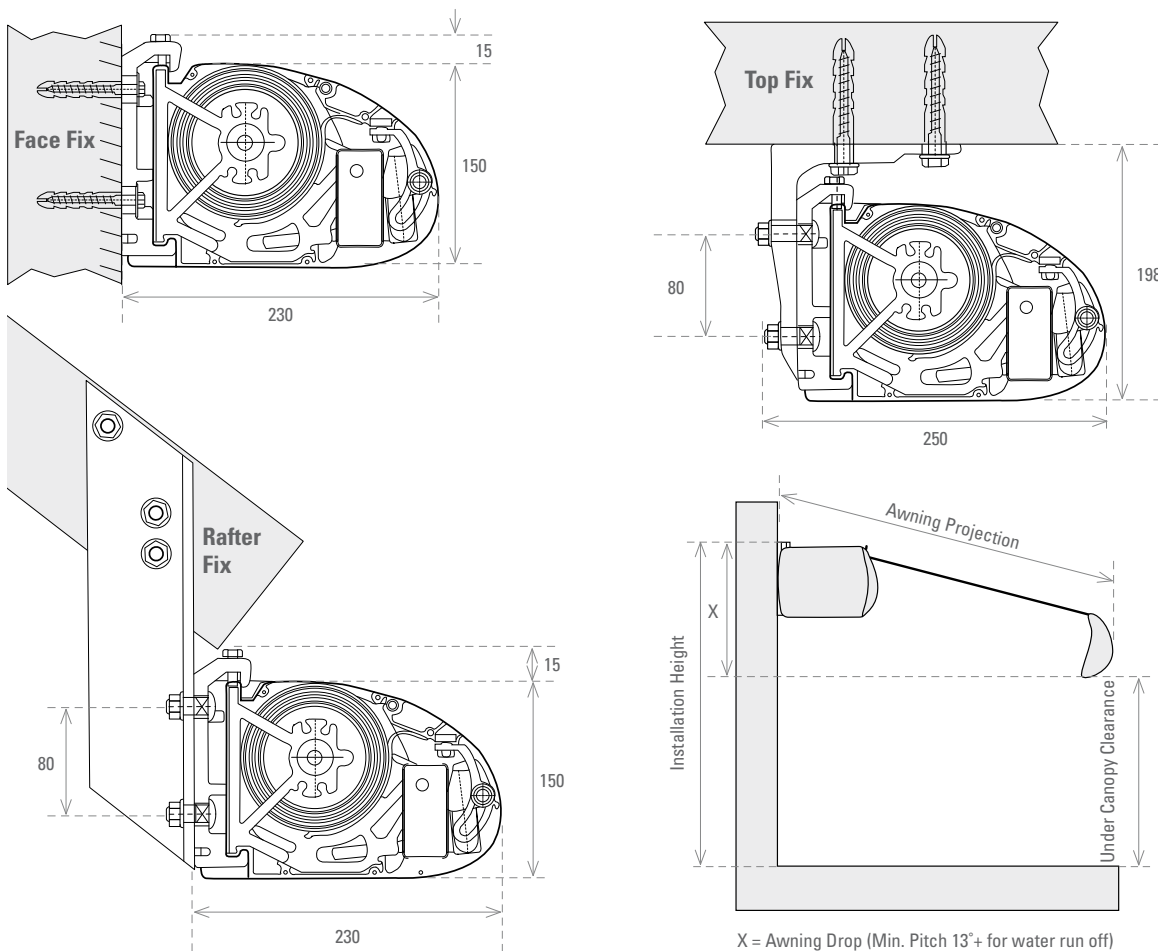

AVAILABLE SIZES

WIDTH	Max. 12000mm (over 7000mm coupled fabric applies) / Min. 2000mm
PROJECTION	Max. 3500mm / Min. 1500mm

HEADBOX

MATERIAL	6061 grade extruded aluminium
DIMENSION	Height: 165mm top/bottom, Depth: 230mm front/back
FINISH	4 standard colours and 300 colours available in the European Custom RAL Powder Coat Range

TOP ROLLER

MATERIAL	80mm diameter heavy-duty extruded aluminium
----------	---

ARM ASSEMBLY

MATERIAL	6061 grade extruded aluminium with 4mm wall thickness
INTERNAL SPRING ASSEMBLY	Heavy-duty 8 gauge tensile steel dual spring assembly with dual 3mm PVC coated 316 stainless steel cable providing unparalleled fabric tension

END CAPS

MATERIAL	Powder coated cast aluminium providing a minimal profile appearance ideal for reveal installations
----------	--

FIXING METHODS

TYPE	Concealed mounting brackets for face fixing, top fix and rafter brackets are also available
------	---

CONTROL OPTIONS

CRANK OPERATION	Cast aluminium, 5.1 ratio, Gear 130X with extruded aluminium crank mechanism
ELECTRIC MOTOR	Tubular motor mounted internally within top roller. Aluminium case complete with built-in limit switches. Extensive range of control options available

FABRIC OPTIONS

MARINE GRADE ACRYLIC	100% dope dyed acrylic "Sunacrylic" fibre - Orchestra, Symphony, Opera ranges are available
SUNSCREEN MESH	High tenacity polyester core yarn sunscreen - Oxygen S5 (5% openness) S15 (%15 openness) ranges

STANDARD COLOUR OPTIONS OR CUSTOM COLOUR ON REQUEST

White/RAL 9010	Natural Anodised	Light Ivory/RAL 1015	Grey Brown/RAL 8019
----------------	------------------	----------------------	---------------------

P 1300 78 28 78

E products@vivascreens.com

Sydney Awning Centre:

1/6 Herbert Street, St. Leonards, NSW 2065

Melbourne Awning Centre:

393 Swan Street, Richmond, Victoria 3121