



SOLIDORA CASSETTE FOLDING ARM AWNING

The compact award winning Solidora Folding Arm Awning provides unparalleled technical strength with the cocoon styled cassette.

- ▶ The unique headbox has been designed and engineered utilising a two piece heavy-duty aluminium extrusion that provides maximum stability and protects all moving components.
- ▶ All components are made from drop forged or extruded aluminium with durable double baked enamel powder coated finish, while 316 stainless steel cables and connectors ensure a long product life with minimal maintenance required.
- ▶ Our textiles offer the very best compromise between visibility and light transmission while providing incomparable weather resistance and ease of maintenance.
- ▶ The Solidora requires only two mounting brackets which are located at each end of the awning, ensuring efficient and uncomplicated installation.
- ▶ Utilising the very latest German engineering and manufacturing techniques, certified ISO9001 safety tested by German TUV (Product Safety Certification).  MADE IN GERMANY



SOLIDORA CASSETTE FOLDING ARM AWNING SPECIFICATIONS

Please note illustrations are not to scale. All measurements are in millimetres. Please contact your Viva Sunscreens representative for additional information.

FIXING METHODS

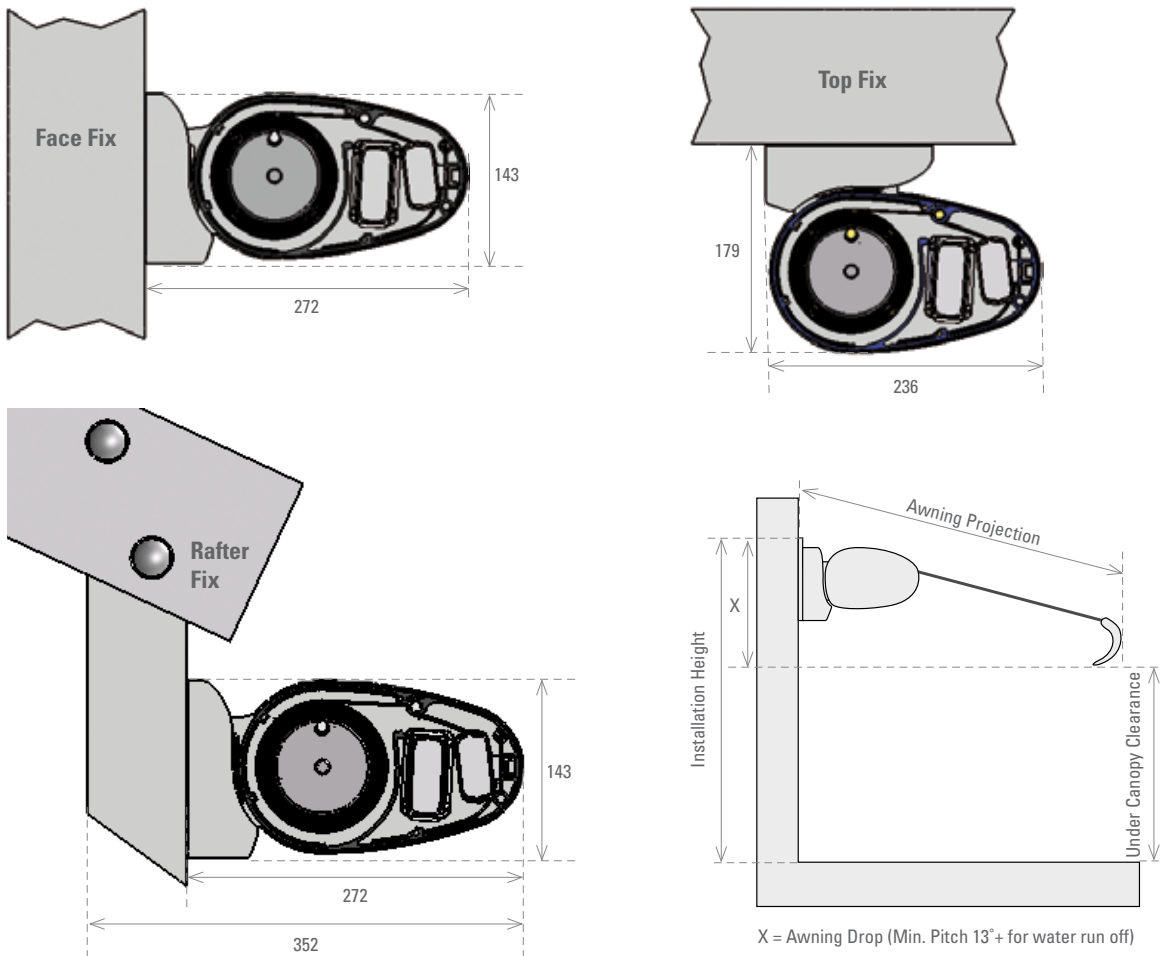

AVAILABLE SIZES

WIDTH	Max. 5000mm / Min. 2000mm
PROJECTION	Max. 3000mm / Min. 1500mm

HEADBOX

MATERIAL	6061 grade extruded aluminium
DIMENSION	Height: 143mm top/bottom, Depth: 272mm front/back
FINISH	Four standard colours and 300 colours available in the European RAL Powder Coat Range

TOP ROLLER

MATERIAL	80mm diameter heavy-duty extruded aluminium
----------	---

ARM ASSEMBLY

MATERIAL	6061 grade extruded aluminium with 4mm wall thickness
INTERNAL SPRING ASSEMBLY	Heavy-duty 8 gauge tensile steel dual spring assembly with dual 3mm PVC coated 316 stainless steel cable providing unparalleled fabric tension

END CAPS

MATERIAL	Powder coated cast aluminium providing a minimal profile appearance ideal for reveal installations
----------	--

FIXING METHODS

TYPE	Concealed mounting brackets for face fixing, top fix and rafter brackets are also available
------	---

CONTROL OPTIONS

CRANK OPERATION	Cast aluminium, 5.1 ratio, Gear 130X with extruded aluminium crank mechanism
ELECTRIC MOTOR	Tubular motor mounted internally within top roller. Aluminium case complete with built-in limit switches. Extensive range of control options available

FABRIC OPTIONS

MARINE GRADE ACRYLIC	100% dope dyed acrylic "Sunacrylic" fibre - Orchestra, Symphony, Opera ranges are available
SUNSCREEN MESH	High tenacity polyester core yarn sunscreen - Oxygen S5 (5% openness) S15 (15% openness) ranges

STANDARD COLOUR OPTIONS OR CUSTOM COLOUR ON REQUEST

White/RAL 9016

Natural Anodised

Light Ivory/RAL 1015

P 1300 78 28 78

E products@vivasunscreens.com

Sydney Awning Centre:

1/6 Herbert Street, St. Leonards, NSW 2065

Melbourne Awning Centre:

393 Swan Street, Richmond, Victoria 3121